

(12) INTERNATIONAL APPLICATION PUBLISHED UNDER THE PATENT COOPERATION TREATY (PCT)

(19) World Intellectual Property Organization
International Bureau



(43) International Publication Date
12 April 2001 (12.04.2001)

PCT

(10) International Publication Number
WO 01/25137 A1

- (51) International Patent Classification⁷: B81B 1/00, (74) Agent: YADAV, Rajiv; McCutchen, Doyle, Brown & Ersen, LLP, Three Embarcadero Center, San Francisco, CA 94111 (US).
G01N 21/05, B01J 19/00, B01L 3/00
- (21) International Application Number: PCT/US00/27313
- (22) International Filing Date: 4 October 2000 (04.10.2000)
- (25) Filing Language: English
- (26) Publication Language: English
- (30) Priority Data:
60/157,565 4 October 1999 (04.10.1999) US
09/453,026 2 December 1999 (02.12.1999) US
- (81) Designated States (*national*): AE, AG, AL, AM, AT, AU, AZ, BA, BB, BG, BR, BY, BZ, CA, CH, CN, CR, CU, CZ, DE, DK, DM, DZ, EE, ES, FI, GB, GD, GE, GH, GM, HR, HU, ID, IL, IN, IS, JP, KE, KG, KP, KR, KZ, LC, LK, LR, LS, LT, LU, LV, MA, MD, MG, MK, MN, MW, MX, MZ, NO, NZ, PL, PT, RO, RU, SD, SE, SG, SI, SK, SL, TJ, TM, TR, TT, TZ, UA, UG, UZ, VN, YU, ZA, ZW.
- (84) Designated States (*regional*): ARIPO patent (GH, GM, KE, LS, MW, MZ, SD, SL, SZ, TZ, UG, ZW), Eurasian patent (AM, AZ, BY, KG, KZ, MD, RU, TJ, TM), European patent (AT, BE, CH, CY, DE, DK, ES, FI, FR, GB, GR, IE, IT, LU, MC, NL, PT, SE), OAPI patent (BF, BJ, CF, CG, CI, CM, GA, GN, GW, ML, MR, NE, SN, TD, TG).
- (71) Applicant: NANOSTREAM, INC. [US/US]; 2275 East Foothill Boulevard, Pasadena, CA 91107 (US).
- (72) Inventors: O'CONNOR, Stephen, D.; 1892 Galbreth Road, Pasadena, CA 91104 (US). DANTSKER, Eugene; Apartment 103, 3710 Garnet Street, Torrance, CA 90503 (US).

Published:

- With international search report.
- Before the expiration of the time limit for amending the claims and to be republished in the event of receipt of amendments.

[Continued on next page]

(54) Title: MODULAR MICROFLUIDIC DEVICES COMPRISING LAYERED CIRCUIT BOARD-TYPE SUBSTRATES

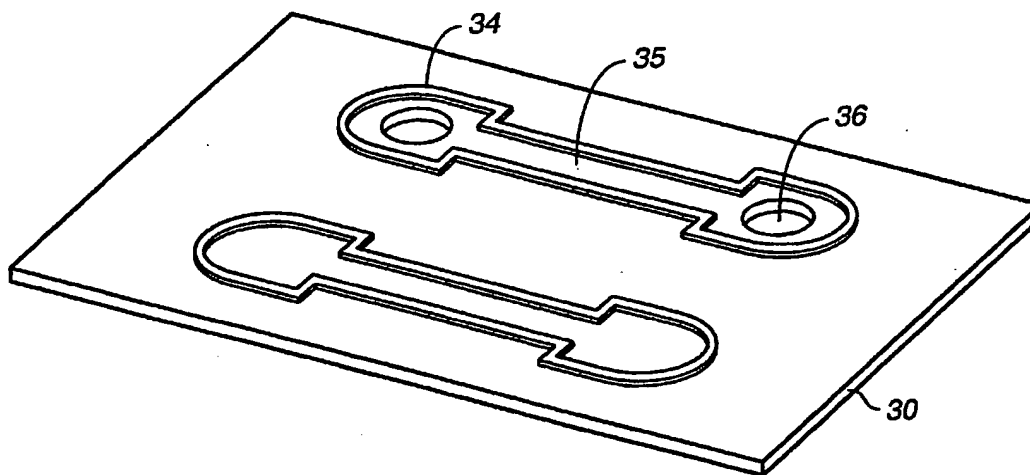

(57) Abstract: The present invention provides modular microfluidic devices and systems, as well as methods for their manufacture. A microfluidic device comprises a first substrate (30) having on at least a first surface thereof at least one microstructure (35) adapted to support a fluid, the microstructure being bounded by metallic features (34), such that the metallic features and the first surface together define inner walls of the microstructure. In addition, the device includes a second substrate (39) sealed to the first substrate to define the microstructure therebetween, the second substrate defining another inner wall of the microstructure, wherein the sealing is provided by an intermediate sealant coat (38) applied to at least a portion of at least one of the first substrate and the second substrate. Preferably, the first substrate is prepared by etching a circuit board comprising a metal (e.g., copper) laminate (31). These microfluidic device can be rapidly prototyped with low tool-up cost, and can be easily assembled to form three-dimensional structures having complex microfluidic system geometries.

WO 01/25137 A1



For two-letter codes and other abbreviations, refer to the "Guidance Notes on Codes and Abbreviations" appearing at the beginning of each regular issue of the PCT Gazette.

MODULAR MICROFLUIDIC DEVICES COMPRISING LAYERED CIRCUIT BOARD-TYPE SUBSTRATES

This application claims the benefit of co-pending U.S. Provisional Application Serial No. 60/157,565, filed October 4, 1999.

5

FIELD OF THE INVENTION

The present invention relates generally to modular microfluidic devices and components that can be combined together to form microfluidic systems. More specifically, the present invention relates to modular microfluidic devices comprising layered circuit board-type substrates, and processes for their
10 manufacture.

BACKGROUND OF THE INVENTION

There has been a growing interest in the manufacture and use of microfluidic devices for the acquisition of chemical and biological information. In particular, microfluidic devices allow, for example, complicated biochemical
15 reactions to be carried out using very small volumes of liquid. These miniaturized devices increase the response time of the reactions, minimize sample volume, and lower reagent cost, among other benefits.

Traditionally, microfluidic devices have been constructed in a planar fashion using techniques borrowed from the silicon fabrication industry.
20 Representative devices are described, for example, in some early work by Manz *et al.* (Trends in Anal. Chem. (1990) 10(5): 144-149; Advances in Chromatography (1993) 33: 1-66). In these publications, microfluidic devices are constructed by using photolithography to define channels on silicon or glass substrates and etching techniques to remove material from the substrate to form the channels. A
25 cover plate is bonded to the top of this device to provide closure. Miniature pumps and valves can also be constructed to be integral with (e.g., within) such devices.

More recently, methods have been developed that allow microfluidic devices to be constructed from plastic, silicone or other polymeric materials. In one such method, a negative mold is first constructed, and plastic or silicone is then poured into or over the mold. The mold can be constructed using a silicon wafer (see, e.g., Duffy *et al.*, Anal. Chem. (1998) 70: 4974-4984; McCormick *et al.*, Anal. Chem. (1997) 69: 2626-2630), or by building a traditional injection molding cavity for plastic devices. Some molding facilities have developed techniques to construct extremely small molds. Components constructed using a LIGA technique have been developed at the Karlsruhe Nuclear Research Center in Germany (see, e.g., Schomburg *et al.*, Journal of Micromechanical Microengineering (1994) 4: 186-191), and commercialized by MicroParts (Dortmund, Germany). Jenoptik (Jena, Germany) also uses LIGA and a hot-embossing technique. Imprinting methods in polymethylmethacrylate (PMMA) have also been described (see, e.g., Martynova *et al.*, Anal. Chem. (1997) 69: 4783-4789). However, these techniques do not lend themselves to rapid prototyping and manufacturing flexibility. Additionally, these techniques are limited to planar (i.e., two-dimensional, or 2-D) microfluidic structures. Moreover, the tool-up costs for these techniques are quite high and can be cost-prohibitive.

Gonzalez *et al.* have described a modular approach to microfluidics (Sensors and Actuators B (1998) 49: 40-45). However, the microfluidic devices described by Gonzalez *et al.* are not truly modular since they are limited to interconnect systems for silicon wafers.

In view of the foregoing, there exists a need for low-cost, prototypable modular microfluidic devices that can be readily combined to construct more complex microfluidic systems. In addition, there is a need for modular, three-dimensional microfluidic devices, which can include various componentry (e.g., valves, filters, etc.).

SUMMARY OF THE INVENTION

The present invention addresses the foregoing needs and provides additional advantages over existing microfluidics technology. The modular approach of the microfluidic devices of the present invention, and the flexibility and low-cost manufacturing processes involved, permit the construction of microfluidic systems comprising “generic” device components which may be easily and effectively assembled or combined to meet a wide variety of design considerations and requirements. The modular design obviates the need for the design and manufacture of costly custom microfluidic systems.

One object of the present invention is to provide an inexpensive and robust modular microfluidic device. An additional object is to provide a microfluidic device that is rapidly prototyped with minimal tool-up costs. The manufacturing cost of the microfluidic devices of the present invention is relatively low, at both high and low production volumes.

Another object of the present invention is to provide a modular system of microfluidic components that can be combined in various configurations to construct a microfluidic device. In this manner, prototyping and manufacturing can be accomplished in a very rapid manner, since a complete set of generic “building block” components can be constructed in bulk. These components and devices can then be combined in various ways to construct desired microfluidic systems.

An additional object of the present invention is to provide “built-in” (i.e., integrated) electronic components within the microfluidic devices. Specifically, for example, electrodes can be placed within channels and chambers of the microfluidic devices. These electrodes can be used for electrokinetic flow, electrophoresis, electrochemical detection, impedance measurements and temperature sensing, among other functions.

Another object of the present invention is to provide a microfluidic device comprising valves for the controlled handling and manipulation of fluids.

Another object of the present invention is to provide a microfluidic device comprising a microstructure capable of filtering a small volume of fluid, especially a fluid comprising biomolecules such as nucleic acids or proteins.

5 Yet another object of the present invention is to provide an inexpensive means of manufacturing positive or negative molds for the construction of microfluidic replicates.

An additional object of the present invention is to provide a microfluidic device that is chemically compatible with or can accommodate the use of a vast array of liquid reagents or solutions including, but not limited to, organic solvents
10 such as acetonitrile.

These and other objects are provided by the present invention. In a preferred embodiment, a microfluidic device is provided comprising a first substrate having on at least a first surface thereof at least one microstructure adapted to support a fluid, the microstructure being bounded by metallic features,
15 such that the metallic features and the first surface together define inner walls of the microstructure. Preferably, the metallic features are elevated relative to the first surface so as to effectively define the lateral boundaries of the microstructure.

A second substrate is sealed to the first substrate to define the microstructure therebetween, the second substrate defining another inner wall of the
20 microstructure. Preferably, the sealing is provided by one or more intermediate sealant coats applied to at least a portion of at least one of the first substrate and the second substrate. The second substrate can optionally have one or more microstructures on a surface thereof.

The first substrate preferably comprises a patterned metal laminate. In a particularly preferred embodiment, the first substrate comprises an etched circuit
25 board. Preferably, the etched circuit board is prepared using chemical etching, plasma etching and/or reactive ion etching techniques. Preferably, the metallic features comprise copper. The first substrate preferably comprises a material selected from the group consisting of fiberglass, polyimide, FR-4, ceramic,

Teflon® and Kapton®. Most preferably, the first substrate comprises fiberglass. In a preferred embodiment, the first substrate is substantially planar.

Preferably, the second substrate (e.g., a cover plate) is substantially planar. In various embodiments, the second substrate can comprise a material selected
5 from the group consisting of Mylar®, polyester, glass, acrylic, polycarbonate and fiberglass.

The sealant coat preferably comprises a silicone material. In other
embodiments, the sealant coat comprises one or more materials selected from the
group consisting of Teflon®, Avatrel®, Liquin®, fluorocarbons,
10 fluorothermoplastics, polyvinylidene fluorides, acrylics, waxes, epoxies, solders,
polymers, paints, oils and varnishes. Preferably, the sealant coat is applied to a
substrate by spin-deposition, spraying or dipping.

The microfluidic device preferably includes one or more microstructures
comprising a channel or chamber. In certain applications, the microstructure is at
15 least partially filled with a filling material, such as a filter material. The filter
material may comprise a wide variety of materials capable of specific and non-
specific filtering of various size parameters. Any of various chemical, biological
and size-exclusion filter materials may be used. In certain embodiments, the filter
material is selected from the group consisting of polycarbonates, acrylics,
20 acrylamides, polyurethanes, polyethylenes, polypropylenes, polyvinylidene
fluorides, polytetrafluoroethylenes, naphion, nylons and polyethersulfones. The
filter material may also be selected from the group consisting of agarose, alginate,
starch and carrageenan. Preferably, the filter material is Sephadex®, Sephacil® or
hydroxyapatite. In a preferred embodiment, the filling material is applied by silk
25 screening, which can reduce the manufacturing time and cost.

In certain embodiments, the microfluidic device includes at least one
substrate having one or more apertures, which can be in fluid communication with
one or more substrates. The microfluidic device may also further comprise one or
more valves of various designs. Several valve configurations and componentry
30 are described below. The microfluidic device can be used to divide a liquid

sample into a plurality of sample. In one embodiment, such splitting of samples is accomplished by using a microstructure comprising one or more forked channels, each preferably having one or more constrictions to control fluid flow therethrough.

5 The microfluidic device may further comprise at least one electrode. The electrode can be used for detecting or measuring an electrical property of a fluid. Alternatively, the electrode is for promoting electrophoretic or electrokinetic flow.

 The microfluidic device may also be used in conjunction with external optical spectroscopy, interrogation and detection. Thus, in certain preferred
10 embodiments, at least a portion of at least one of the substrates in the microfluidic device is adapted to permit transmission of an optical signal (i.e., is sufficiently optically transparent).

 The microfluidic device of the present invention may be multi-layered to form a three-dimensional device or system. Therefore, in certain embodiments,
15 the microfluidic device may further comprise one or more additional substrates sealingly engaged thereto. The additional substrate(s) are preferably layered or stacked so that microstructures of the various layers are sufficiently aligned as to be functional for the desired application. In addition, a microfluidic system comprising a plurality of microfluidic devices may be constructed, wherein at least
20 two of the microfluidic devices are configured to enable fluid communication with each other. The microfluidic system can be prepared by layering two or more microfluidic devices to form a three-dimensional microfluidic system.

 The present invention also provides a method for producing a microfluidic device. The method comprises the steps of: (a) preparing a first substrate having
25 on at least a first surface thereof at least one microstructure adapted to support a fluid, the microstructure being bounded by metallic features, such that the metallic features and the first surface together define inner walls of the microstructure; and (b) sealing a second substrate to the first substrate to define the microstructure therebetween, the second substrate defining another inner wall of the
30 microstructure. Preferably, the sealing is provided by applying an intermediate

sealant coat to at least a portion of at least one of the first substrate and the second substrate before sealing. In a preferred method, the sealant coat is applied by spin-deposition. Preferably, the first substrate is prepared by etching a circuit board comprising a metal laminate. Such etching can create metallic features defining a
5 microstructure. The present invention also provides a microfluidic device prepared according to the foregoing method.

Definitions

The term "microfluidic" as used herein is to be understood to refer to microstructures wherein one or more of the dimensions is less than 500 microns,
10 as well as to components, devices and systems comprising such microstructures. The microfluidic devices of the present invention can be planar (i.e., approximately two-dimensional, or 2-D) or three-dimensional (3-D). Additionally, such devices can be constructed using any of the materials described herein, as well as combinations of such materials, and similar or equivalent materials.

15 The term "microstructure" as used herein refers to microfluidic structures disposed on one or more substrates used to assemble the microfluidic devices of the present invention. The term encompasses any of a variety of structures (including, but not limited to, channels and chambers) that are capable of supporting a fluid (i.e., microstructures through or into which fluid(s) are capable
20 of being passed, stored or directed). The microstructure boundaries are defined by metallic features (e.g., lines) disposed on at least a first substrate. Such metallic features are preferably elevated, so as to effectively define the lateral boundaries of the microstructure. The metallic features may be formed by depositing features comprising metal onto a substrate or, alternatively, by coating substrate features
25 with a material comprising a metal.

The term "sealed" as used herein refers to a microstructure having a sufficiently low unintended leakage rate and/or volume under given flow, fluid identity and pressure conditions. The term also encompasses microstructures that have one or more apertures therein through which fluid is intended to pass.

The term "channel" or "chamber" as used herein is not intended to be restricted to elongated configurations where the transverse or longitudinal dimension greatly exceeds the thickness, depth or cross-sectional dimension. Rather, such terms are meant to comprise cavities or tunnels of any desired shape or configuration into or through which liquids may be directed or passed. Such a fluid cavity may, for example, comprise a flow-through channel where fluid is to be continually passed or, alternatively, a chamber for holding a specified, discrete amount of fluid. "Channels" and "chambers" may be filled or may contain internal structures comprising, for example, valves, filters, and similar or equivalent components and materials.

The term "circuit board-type substrate" as used herein refers to circuit board substrates, as well as to substrates generally having a metal laminate capable of being etched and patterned to form metallic features (e.g., lines) defining a microstructure.

The microfluidic devices described here are "generic" in that they are modular and can be easily reconfigured into or adapted to any design. These devices are capable of being used with a variety of pumping and valving mechanisms, including pressure, peristaltic pumping, electrokinetic flow, electrophoresis, vacuum and the like. In addition, the microfluidic devices of the present invention are capable of being used in collaboration with optical detection (e.g., fluorescence, phosphorescence, luminescence, absorbance and colorimetry), electrochemical detection, and any of various suitable detection methods. Suitable detection methods will depend on the geometry and composition of the device. The choice of an appropriate detection method for a given application is within the purview of the skilled artisan.

BRIEF DESCRIPTION OF THE DRAWINGS

Figure 1 provides cross-sectional views showing the steps (A, B and C) used to etch a circuit board-type substrate comprising a metal laminate to form

metallic features (i.e., lines and shapes) defining the boundaries of a microstructure (here, a microfluidic channel).

5 Figure 2 is a perspective view showing a microfluidic channel defined by metallic lines on a circuit board-type substrate. Inlet and outlet apertures can be provided in the underlying substrate.

Figure 3 provides cross-sectional views (A-D) showing a circuit board-type substrate being coated with a sealant coat. A second substrate (e.g., a cover plate) layered upon and sealed to the circuit board-type substrate can optionally also be coated with a sealant coat, as in Figure 3D.

10 Figure 4 is a cross-sectional view showing a microfluidic device where one sealant coat material is used to coat the circuit board-type substrate having a microstructure thereon, and a second intermediate sealant coat material is used to help seal the substrates together.

15 Figure 5A is a cross-sectional view of a microfluidic device constructed using circuit board-type substrates having metallic features on a single side of each substrate. Figure 5B is an exploded perspective view of an example of such a microfluidic device.

20 Figure 6 is a cross-sectional view of a microfluidic device constructed using circuit board-type substrates having metallic features on both sides of several of the substrates.

Figure 7 illustrates the use of silk screening technology to fill or coat specific areas (e.g., chambers) of a microfluidic device. Figure 7A shows the individual components, and Figure 7B shows an alignment procedure.

25 Figure 8 is an exploded perspective view of a microfluidic device that has an integrated (i.e., "built-in") valving mechanism.

Figure 9 is a top view of a microfluidic device comprising forked channels capable of splitting a sample into four approximately equal parts.

Figure 10 illustrates the components of a microfluidic device that has an integrated (i.e., "built-in") valving mechanism.

Figure 11 is an exploded view showing an alignment technique using peg-and-hole alignment technology to ensure proper alignment of various layers and componentry of a microfluidic devices.

5 Figure 12A shows top and bottom perspective views of a microfluidic device with a built-in electrode heating system. Figure 12B shows top and bottom perspective views of a microfluidic device with a built-mechanism for applying or detecting a magnetic field.

Figure 13 is a photomicrograph of a silicone-coated channel in a microfluidic device through which water is being passed.

10 Figure 14 is a photomicrograph of a Teflon®-coated channel in a microfluidic device through which water is being passed.

Figure 15 shows the construction of a microfluidic device comprising both circuit board substrates and stencils. Figure 15A illustrates an exploded perspective view and Figure 15 B illustrates an assembled perspective view.
15 Figure 15C is a photomicrograph of a device as shown in Figure 15B with fluid passing therethrough.

Figure 16 shows a microfluidic device that is useful for electrokinetic flow or for electronic detection. Figure 16A is an exploded top perspective view of the device, and Figure 16B is an exploded bottom perspective view of the device.

20 **DETAILED DESCRIPTION OF
PREFERRED EMBODIMENTS OF THE INVENTION**

Referring to Figure 1, a microfluidic device structure is constructed using a standard, commercially available circuit board substrate. In Figure 1A is shown a circuit board substrate 10 comprising an underlying substrate 30 having thereon a layer of metal laminate 31 on one side. Circuit board substrates for use in the present invention can have metal laminate layers on either or both surfaces.
25 Referring to Figure 1B, a photoresist layer or mask 32 is patterned onto the surface in any desired pattern, and the unprotected metal laminate is subsequently removed (see Figure 1C) using any of various methods known in the art, such as

chemical etching or plasma etching, among others. The remaining (protected) metallic features (e.g., lines) 33 form the boundaries of the microstructures (e.g., channels or chambers) formed on the circuit board substrate. The remaining photoresist can be removed with chemical solvents.

5 Figure 2 shows one circuit board configuration where metallic features 34 form the boundaries of a channel 35. A second, planar substrate layer (not shown) can be brought into contact with (i.e., laid upon) the metallic features 34 to complete or "cap" the channel 35. Apertures 36 can be formed (e.g., drilled) through the substrate 30, such apertures being useful as inlet and/or outlet
10 apertures. Alternatively, access to the channel 35 can come from an adjacent substrate layer. Other types and shapes of inlet and outlet apertures can be used.

 A variety of circuit board substrate and metal laminate compositions are suitable, including many commercially available products. Preferably, the metal laminate comprises copper. The copper laminate can optionally be coated (e.g.,
15 plated) with nickel and/or gold. Preferably, the copper laminate is coated with both nickel and gold, in such order. This and other metal layer coatings are known in the art and can be used to make the metal laminate more inert (i.e., less chemically reactive), or to make the metal laminate have better electrical characteristics (e.g., better conductivity for use as an electrode in electrochemical
20 applications). Other suitable metals can be coated onto the copper; such metals are known or ascertainable by those skilled in the art.

 Preferably, the circuit board substrate comprises fiberglass, but other substrate materials can be used. Examples of suitable substrate materials include polyimide, FR-4, ceramics, and Teflon®, among others. Circuit boards made
25 from these materials are commercially available. Flexible substrate materials can also be used, and can be used in more varied applications. In certain embodiments, the entire (i.e., assembled) microfluidic device is structurally flexible. Kapton® (Dupont, Wilmington, DE) is one example of a suitable substrate material that is flexible.

The thickness or height (and, thus, the volume) of the microstructures can be controlled by varying the thickness of the metal laminate layer on the substrate. Standard metal laminate thicknesses are described typically by weight. For example, for copper laminated circuit boards: ½ ounce = 17.5 microns thick; 1
5 ounce = 35 microns thick; and so on. Thinner laminate layers (e.g., ¼ ounce and less) are now commercially available.

Referring to Figure 3, at least a portion of the surface of the etched circuit board substrate 30 can be coated with a layer of a sealant coat material 38. A cover plate substrate 39 (which is preferably substantially planar) can be layered
10 upon the circuit board substrate 30 and the metallic features 33 to “cap” or complete the microstructure 35 defined thereby. In Figure 3C, the cover plate substrate 39 is not coated. In Figure 3D, the cover plate substrate 39 is coated with a sealant coat material 41, which can be the same as or different than the sealant coat material 38.

15 Numerous suitable sealant coat materials having various desired properties can be used. The sealant coat material can be chemical and/or biological in nature, and can be hydrophobic or hydrophilic, depending on the application. Solids, liquids, gels and powders, or combinations thereof, can be used. Materials capable of carrying a surface charge can be used, as can neutral species. Specific
20 examples of coating materials suitable for use in the present invention include Teflon®, Liquin®, Avatrel®, silicone, silicone mixtures, epoxies (including solder masks), glue, liquid polymers, polymeric dispersions, plastic, liquid acrylic, paint, metals, oils, waxes, photoresist, varnish, solder and glass.

In a preferred embodiment, the sealant coat material is a polymer, such as,
25 for example, polyethylene glycol and cyanoacrylate. In other preferred embodiments, the coating material is biological in nature. Advantageously, in various applications, the biological coating material can be used to either promote or prevent adherence of materials. In certain embodiments, a biological coating material (e.g., a ligand) that specifically binds to certain biological materials is
30 preferred. Examples of biological coating materials include proteins, antibodies,

lipids, cells, tissues, nucleic acids and peptides. More specific examples include avidin, streptavidin, poly-lysine, and enzymes. In certain embodiments, the coating materials are used to selectively bind materials that are present in the samples.

5 In another preferred embodiment, the sealant coat material is a fluorinated polymer. Fluorinated polymers have excellent resistance to various solvents and chemicals, including organic solvents. Examples include Teflon®, Avatrel®, polyvinylidene fluoride (PVDF), THV Fluorothermoplastic (Dyneon, St Paul MN), Hostaflon TF 5035 (Dyneon), among others.

10 In a preferred embodiment, the sealant coat serves to both coat and seal a microstructure. In Figure 4, a thin layer of a sealant coat material 38 is applied to the circuit board substrate 30 and metallic features 33. Dabs of a second sealant coat (epoxy) 44 help to seal the cover plate substrate 39 onto the circuit board substrate 30 to define a channel 35 therebetween. The epoxy sealant coat can be
15 added either before or after sealant coat 38 has been cured.

 In one embodiment, heat and/or energy is used to anneal the sealant coat. Examples include melting the layers together. Another example is to use heat-activated tape.

 The various sealant coat material(s) can be deposited onto a substrate using
20 a number of techniques. In a preferred embodiment, the sealant coat material(s) are spin-deposited onto a given substrate using a spinner or rotator. Specifically, an appropriate amount of a sealant coat material is placed on a substrate and the entire substrate is spun to produce a generally uniform sealant coat layer. In a preferred embodiment, the spin rate is between about 10 rotations per minute
25 (rpm) and about 100,000 rpm. More preferably, the spin rate is about 500-20,000 rpm and, most preferably, is about 1,000-20,000 rpm. In order to make the coating thicker, multiple spin-deposition cycles can be used.

 Alternatively, the sealant coat material can be deposited by spraying the sealant coat material onto a substrate. For example, the sealant coat material can
30 be ultrasonically sprayed through a nozzle or other orifice. In one embodiment,

colloidal dispersions of the sealant coat material are prepared, the concentration being adjusted so that when sprayed onto a substrate, a layer of desired thickness results. In another embodiment, the sealant coat material is sprayed directly onto a surface. In yet another embodiment, the sealant coat material is dissolved in an appropriate solvent and then sprayed onto the surface; when the solvent evaporates, the sealant coat material is left behind to form a coating layer. The sealant coat material can, alternatively, be applied by dipping the substrate into a volume of the sealant coat material. A single dip may produce a coating of a certain thickness; in order to make the coating thicker, multiple dips may be applied. Alternatively, the sealant coat material can be brushed onto the surface. As with the spraying techniques described above, the sealant coat material can be deposited directly as a colloidal dispersion, or as a material dissolved in a solvent. In another preferred embodiment, the sealant coat material is stamped onto the surface.

In a preferred embodiment, the sealant coat material is patterned (e.g., by silk screening techniques) onto a substrate. In this embodiment, the sealant coat material can be used to coat only certain selected areas of the substrate as defined by the mask. In another preferred embodiment, photoresist patterning can be used to achieve liftoff or etch patterning. The photoresist can then be removed to leave a coating only on certain areas of the surface. This procedure can be repeated as desired or necessary using different photoresist patterns and coating materials.

In alternate embodiments, a variety of thin film deposition techniques can be used to deposit sealant coat materials. Such techniques include, but are not limited to, thermal evaporation, e-beam evaporation, sputtering, chemical vapor deposition, and laser deposition. These and other thin film deposition techniques are well known in the art. In addition, plating techniques can be used to deposit sealant coat materials. Such plating techniques include, but are not limited to, electroplating of metallic materials and chemical plating.

The thickness of the sealant coat may be important in certain embodiments. Preferably, the thickness of the coating is sufficient to chemically protect the

underlying substrate and/or to adhere or seal an adjacent substrate. A potential problem of too thick a coating is the obstruction or blockage of microstructures, which can impede or prevent fluid flow therein.

Where the sealant coat material does not solely serve an adherence
5 function, thinner coatings can be used. In fact, a molecular layer (or monolayer) may be preferable in certain instances. In a preferred embodiment, the sealant coat is a self-assembled monolayer of alkane thiols, which is particularly amenable to deposition on metal surfaces such as gold. Other similar thiols can be used. In
10 another preferred embodiment, silanization reactions can be used to coat the substrates. Silanization is known to minimize adherence of certain biological materials such as nucleic acids and peptides. In yet another preferred
15 embodiment, the microstructures are coated with a lipid bilayer or multilayer. In certain embodiments, these molecular monolayers are terminated with a biological molecule that is used to bind a molecule in the solution. Examples include nucleic acid-terminated alkane thiols and protein-terminated silanes.

In certain embodiments, a secondary mechanism may be used to help seal
substrates together. In certain embodiments, substrate layers are held together
mechanically. Examples include using nuts and bolts, tight-fitting pegs and holes,
epoxy, BLU-TEK®, or an external clamp. Alternatively, pressure or vacuum can
20 be used to accomplish this mechanical adhesion or sealing.

It is sometimes necessary to adjust the viscosity of the sealant coat material
prior to the substrate coating step. In order to obtain a desired viscosity, some of
the sealant coat materials may need to be diluted or thinned with other solvents or
chemicals. Alternatively, the sealant coat materials can be heated prior to their
25 deposition to alter their viscosity. Appropriate viscosity adjustments will be
apparent to those skilled in the art.

Substrates to be coated are preferably cleaned prior to the coating and
adhesion steps. Examples of cleaning techniques include soaking, sonicating,
rinsing and plasma cleaning. Examples of cleaning materials include soap,
30 surfactants, detergents, organic solvents and Freon®.

The layers or components of the modular microfluidic devices of the present invention can be combined or assembled to produce three-dimensional microfluidic devices and systems. Such systems can have complex geometries. Referring to Figure 5, a three-dimensional microfluidic device is constructed. A first substrate 48 is constructed according to any of the techniques described above. Instead of covering this first substrate 48 with a cover plate substrate, a second substrate 49 having defined microstructures (e.g., channels and/or chambers) is sealed to the first substrate 48. Additional substrates, such as 50, can be layered and sealed thereto to assemble a microfluidic device. The final layer, as in Figure 5A, may be a cover plate substrate 39. Apertures 52 can be formed in the substrate layers at positions so that the apertures are aligned or in fluid communication with each other as desired such that fluid can traverse between adjacent substrate layers. Figure 5B is an exploded perspective view showing how the individual substrate layers may be stacked so that various features or components on each substrate layer are properly aligned and in fluid communication to create a 3-D microfluidic device.

Methods of forming apertures include, but are not limited to, mechanical drilling, laser drilling, chemical etching, plasma etching and hole punching. Alternatively, cover plates and/or layers of the device can be constructed from injection molded parts that have integrated or built-in inlet/outlet apertures. Other techniques known in the art for through-hole formation can be employed.

Another three-dimensional microfluidic device is shown in Figure 6. In this embodiment, certain of the circuit board substrates 53 have double-sided metal laminates from which metallic features 54 can be formed. In this manner, microstructures such as channels and/or chambers can be defined on both sides of the substrates. Planar substrates or cover plate substrates 55 can be placed between the substrate layers and at the top and bottom of the device. Apertures 56 can be formed in the circuit board substrates and cover plate substrates to provide fluidic feed-through between substrate layers. In this embodiment, a single cover

plate substrate can define both the top inner surface of one microstructure and the bottom inner surface of another microstructure (see Figure 6).

In certain embodiments, the sealant coat materials can be chemically bonded to the underlying substrate and to the next layer. Alternatively, non-covalent chemical interactions can be used to hold the substrates together.

A stencil defining a microstructure may comprise one or more layers of a microfluidic device. The stencil material can be melted onto the underlying substrate or adhered using an adhesive or some other mechanism, such as heating. In other embodiments, the stencil material can be mechanically pressed onto the underlying substrate. The use of stencil materials in constructing microfluidic devices is the subject of co-pending United States Patent Application Serial No. _____ (Attorney Docket No. _____), the disclosure of which is incorporated herein by reference.

In a preferred embodiment, a microstructure can be filled with any of a variety of filling materials, including reagents or catalysts. These filling materials, in certain embodiments, can be used to perform useful chemical and/or biological reactions. In a preferred embodiment, the filling materials are filters, which are useful for separating and/or purifying materials. These filters can be chemical or biological filters, or size-exclusion filters. These filters may bind unwanted material or, alternatively, may bind the material of interest so that it may be eluted off later. The filling materials can be hydrophobic or hydrophilic in nature, and can be charged or neutral. The filling material may be porous with various pore sizes. In a preferred embodiment, the filling material used to fill a channel or chamber is polymeric. Examples include, but are not limited to, polycarbonate, acrylic, polyurethane, high-density polyethylene (HDPE), ultra-high molecular weight polyethylene (UHMW), polypropylene (PP), polyvinylidene fluoride (PVDF), polytetrafluoroethylene (PTFE), naphion, nylon, and polyethersulfone (PES). In a preferred embodiment, the material used to fill the channel is a carbohydrate, such as agarose, alginate, starch, or carrageenan. The polymer may also be an electro-active polymer. In a preferred embodiment, the filling material

is silica gel. In another preferred embodiment, the filling material is Sephadex® or Sephacil®. In another preferred embodiment, the material used to fill the channel is acrylamide or agarose. In another preferred embodiment, the material used to fill the channel is hydroxyapatite.

5 In a preferred embodiment, the filling material used to fill the channel and/or chamber is a biological material. Examples include, but are not limited to, binding proteins, antibodies, antigens, lectin, enzymes, lipids, and any molecules that may interact specifically or non-specifically with one or more of the species in the fluid.

10 In a preferred embodiment, the filling material is composed of a powder, such as charcoal or porous beads. In another preferred embodiment, the filling material is a reagent that is to be activated during the use of the device. Two examples are soluble reagents and catalysts.

15 In a preferred embodiment, the filling material is a paper filter. This filter may be a commercially available material that is chemically modified to perform a specific function, such as binding a material or filtering a variety of materials.

20 In a preferred embodiment, the materials placed in the microstructures perform useful biological or chemical functions. Examples include solid buffer materials that can be used to buffer a sample once injected. Other materials include lysis buffer for lysing cells and solid reagents. Catalysts can also be placed within the devices.

25 In a preferred embodiment, the filling material is composed of a single component that is already formed prior to being placed into a microstructure. Alternatively, the material can be formed from multiple components that can be separately placed into a channel; once in the channel, the materials can react to form the final filling material. Such curing can be accomplished in a variety of ways, and can be spontaneous or catalyzed by some other mechanism such as light, heat, a catalyst, solvent, drying, etc.

30 In one embodiment, the filling material is placed into the microstructures during the manufacturing process. In this manner, high-throughput techniques can

be used to fill the channels. In one embodiment, high-throughput pick-and-place equipment, like that used in the electronics industry, is used to place the filter materials.

In one embodiment, the filling material is patterned into the
5 microstructures by, for example, silk screening the material into the channels, or by using lithography, or by mechanically placing the material. Referring to Figure 7A, an "empty" microfluidic device 90 having two filter chambers 91 and 92 is shown. In order to place filter material in the filter chambers 91 and 92, two silk screens 93 and 94 are created. The screen and stencil are formed using materials
10 that are compatible with the filter to be screened. A variety of screen materials and stencils can be used. One of the screens is aligned, for example, above the device and the first filter material 95 from screen 93 is screened onto the device. The second filter material 96 can subsequently be screened onto the device from screen 94 in a similar fashion to create the completed device 98. The viscosity and
15 thickness of the material to be screened is preferably adjusted to properly fill the filter chamber or other filter area. Additionally, the amount of screened-on material can be adjusted after placement so that the chamber fills properly.

In a preferred embodiment, an entire panel of devices can be coated simultaneously. Referring to Figure 7B, circuit board devices are constructed on a
20 panel 111. A preferred panel size is approximately 18'' by 24''; however, other panel sizes may be used. Fiducial marks 114 are placed on the panels for visual or optical alignment. Holes placed in the circuit board are used to align the circuit board on the various machines used during the device manufacturing process. Silk screens 112 and 113 comprising filter material are aligned with the devices on
25 panel 111. A single alignment allows all of the filter chambers (see 115 and 116 denoting the two types of filter chambers on the panel 111) to be filled simultaneously. Finally, cover plates and/or additional substrate layers may be added to complete a microfluidic system.

In a preferred embodiment, one or more of the layers of a microfluidic
30 device of the present invention can be used as a valve. Referring to Figure 8, a

multi-layer purification device is constructed. An inlet aperture 100 and an outlet aperture 101 are constructed in a top substrate layer 102. In one embodiment, this substrate layer can be a thin piece of acrylic, glass or polycarbonate. A circuit board substrate forms the next layer below. In this layer, a filter chamber 104 is
5 constructed and filled with an appropriate filter material (not shown) by, for example, silk-screening. Referring again to Figure 8, a T-shaped feature is formed, where one arm of the T is a chamber 105 and the other arm is a channel 103. A hole 106 is located at the distal end of the chamber 105. Channel 103 is in communication with outlet aperture 101 in the top substrate layer 102. The
10 bottom substrate layer 110 of the stack comprises a filter material that allows air to flow but that becomes blocked when liquid comes into contact with it. Examples of such filter materials include X-7744, a 7 μm pore size T3 sheet from Porex Technologies (Fairburn, GA) and Goretex®-type materials. In operation, a sample is injected into the inlet aperture 100. The sample flows through the filter
15 material in chamber 104 and into "wide" chamber 105 and "large" hole 106 until sufficient volume has been injected to fill that chamber and hole. Then, the fluid flows into "narrow" channel 103 and out through outlet aperture 101. Any number of mechanisms can be used to force the fluid to preferentially flow into the larger chamber 105 first. Capillary forces may be taken advantage of.
20 Alternatively, the channels may be coated with materials that induce preferential flow.

In another preferred embodiment of the invention, flexible coating materials can be used on certain layers of the device in order to enable valving and pumping mechanisms. Examples include silicone rubber and viton. Pressure or
25 mechanical force can be applied to the flexible layer to cause the material to bend and block a channel located above or below it.

An alternative valving mechanism can be used where pressure and/or vacuum is applied to inlet and outlet apertures from an external source. Rate of fluid flow can be controlled by varying the external pressure or flow of the input
30 mechanism. Examples include the use of a syringe or peristaltic pump.

Alternatively, lateral microconstrictions can be defined in a channel to limit the rate of flow. Alternatively, vertical constrictions can be added inside a channel. These constrictions can also be used to facilitate mixing. Alternatively, rate of flow in a network of channels can be limited or controlled by forcing the liquid through a channel or portion thereof coated with a compound more hydrophobic than the rest of the network.

In a preferred embodiment, a microfluidic device is used to concentrate samples. The device is constructed so that the volume of the wide channel/chamber and the large hole is about 2-100,000 times larger than the remaining filter chamber and channel volume. A large sample can be injected and washed many times. Then, a very small volume of eluent can be added to remove the sample that had been adhered to the filter material in filter chamber 104. In another preferred embodiment, valves are constructed by altering the shapes of the channels themselves. Referring to Figure 9B, a device is created having multiple channel splits or forks 120. After each split, the channels are constricted (see 122 in Figure 11B) so that local capillary forces are increased in that region. Further splits can be constructed after the constricted region. Referring to Figure 9B, as a sample enters a split or fork, the fluid typically will preferentially pass down one of the two channels of the split. However, once the fluid reaches the constriction area, the other of the two channels becomes filled because the capillary forces in this region are much less than in the constricted section. Once both channels are filled, the fluid passes the constriction regions to the next channels, and so on. Using this approach, samples can be accurately distributed into approximately equal portions. A three-dimensional device using this design should permit samples to be split into many partitions.

In another preferred embodiment, a valve is constructed by altering the outlet apertures for each channel. Referring to Figure 10C, a microfluidic device is constructed that has a large primary channel 125 with a smaller branched channel 126. The primary channel 125 terminates in channel 127, which is narrower than channels 125 and 126. A cover plate substrate 128 with inlet and

outlet apertures positioned at the end of each of the aforementioned channel forms the top substrate layer. When fluid enters the main inlet aperture 129, the fluid flows first down the primary channel 125. When the fluid reaches the junction of channel 127, the capillary forces are sufficient to force the fluid down channel
5 126.

The surface chemistry of the various channels may be altered in order to achieve the same goal. In one embodiment, the end of a large channel is coated with a hydrophobic material, while the rest of the channels are hydrophilic. When water enters the large channel, it first passes down the large channel. When it
10 reaches the area where the channel has been derivatized with hydrophobic terminal groups or coatings, surface tension forces the remainder of the water down the smaller, hydrophilic channels. Similar techniques can be used with organic solvents.

With multi-layered microfluidic devices, alignment of the layers is a
15 consideration. Therefore, preferably, automated techniques will be used for this alignment. Additionally, the construction of these devices will be done in parallel so that a single alignment can be performed for the construction of a multitude of devices. In a preferred embodiment, peg-and-hole techniques are used to align the layers. Referring to Figure 11, a manifold 130 is constructed having dowels 132
20 of specified diameter. A panel 134 of circuit board devices is coated and placed on the manifold 130; alignment is accomplished by aligning holes 135 with the dowels 132. An adjacent layer 136 is coated and placed atop panel 134; similarly, alignment is accomplished by aligning holes 137 with the dowels 132. Once all of the layers are in place on the manifold, curing of the entire device can be
25 completed. Such manifolds can also be used to accommodate silk screens. A similar manifold system is useful in the construction of stencil-based microfluidic devices.

In another preferred embodiment, edge alignment is used. The edges of the devices are aligned, which automatically aligns the channels and chambers if the
30 devices are cut to specified dimensions. Alignment can be accomplished

mechanically, optically, magnetically, or otherwise. In a preferred embodiment, a panel of devices are simultaneously aligned and processed. The completed panel of structures may then be cut or sectioned into individual devices. In a preferred embodiment, the component layers are scored into device sections prior to
5 assembly.

In another preferred embodiment, the layers of the device are brought in close proximity, realigned, and then pressed together. In this and other embodiments it may be important to control the humidity and temperature of the environment surrounding the layers. Often, the coating materials and adhesives
10 cause local static interactions between the layers, making alignment difficult. In an additional embodiment, the layers can be aligned under water, to minimize the static. In another embodiment, a small amount of soap is added to the water to prevent immediate adhesion if a slight misalignment occurs. In another embodiment, the temperature of the local environment surrounding the layers is
15 controlled in order to aid in alignment.

In another embodiment, a press is constructed that has alignment blocks on both the top plate and bottom plate. One layer of the device is placed in the bottom alignment jig, and the next layer is placed in the top alignment jig. The automated press then brings the devices together for adhesion. When the press is
20 expanded, the two layers stay on the bottom block. The next layer can be applied in a similar manner.

In certain embodiments, flexible circuit board substrates are used to aid in the alignment procedures. In certain embodiments, a rolling system could be used to fill channels and chambers. The roll of devices is pulled across an alignment
25 block and filter material is added. Again, alignment may be accomplished using a peg-and-hole alignment block. However, other alignment techniques may be used, including optical alignment and precision placement.

In a preferred embodiment of this invention, metal lines can be added that serve a function other than defining channels. In one embodiment, electrodes are
30 placed in the channels and chambers to perform interesting detection and/or

activation techniques. Examples include electrophoresis, electrokinetic flow, electrochemical detection, impedance detection, capacitive detection, heating and measuring current or voltage. In another embodiment, interesting structures are created to induce other phenomena. Referring to Figure 12A, the metal lines can
5 be zig-zagged within a channel or chamber. Current can be passed through the metal lines to induce heating within the chamber. Thermocouples can be constructed within the chamber using the metal lines to detect thermal changes. Calorimetry can be performed in this manner. Referring to Figure 12B, a magnetic field can be induced in a similar manner. This magnetic field can be
10 used to detect certain phenomena or induce flow using magnetic particles.

In another preferred embodiment, the circuit board structures are not used as the fluidic devices themselves, but rather they (or portions thereof) are used as forms to define a positive or negative mold. Various molding materials can be used, such as moldable polycarbonate or various silicones (see, e.g., Duffy *et al.*).
15 Microfluidic devices can then be prepared comprising microstructures formed using such molds.

The following Examples describe certain aspects of several preferred embodiments of the present invention and are not intended to be limiting in any manner. Rather, the scope of the present invention is defined by the claims
20 appended hereto. Other materials and configurations, not specifically disclosed herein, are also contemplated. Such alternate embodiments will be apparent to one of ordinary skill in the art in view of the present disclosure.

EXAMPLES

Example 1

25 A microfluidic channel was constructed as shown in Figure 2. Copper lines 34 were formed by photolithographically patterning and chemically etching a 2 oz. (70 micron thick) copper laminate supported on a 0.062" thick FR-4 (Circuit Connection, Orange, CA) substrate 30. The channel 35 was 0.012" wide (at its widest point) and 0.25" long, producing a channel volume of approximately 136

nl. Inlet/outlet apertures 36 (0.040" diameter) were drilled into the substrate 30 as shown in Figure 2.

The device was cleaned by rinsing with methanol. A sealant coat material was prepared by mixing 1.30 grams of RTV silicone mold-making rubber (product # CK1110B), 0.13 grams of activator (Product # 179A CLR) and 1.00 gram of lacquer thinner. This mixture was placed in a desiccator and the air was evacuated with a mechanical vacuum pump for two minutes to degas the material. After degassing, 2.00 grams of lacquer thinner and 0.06 grams of Ultrafast® Catalyst (Product # UFC 19170) were added and the material was thoroughly mixed by stirring. The silicone, activator and catalyst were all purchased from Circle K® products (Temecula CA). The lacquer thinner (main component: petroleum naphtha) was manufactured by Bortz Products (Santa Fe Springs, CA). The substrate was placed onto a spinner and approximately 300 µl of the sealant coat mixture was spin-deposited onto the surface. The substrate was spun at 3100 rpm for 30 seconds. The spin-deposition procedure was repeated twice. As a cover plate substrate (not shown), a 1/16" thick piece of acrylic was cut to fit the size of the substrate 30. The cover plate substrate was coated twice with the sealant coat mixture using the same procedure. The two substrates (i.e., the circuit board and the cover plate) were placed face-to-face and allowed to cure overnight at room temperature.

A small, disposable pipette tip was inserted into the inlet aperture 36 and water (colored with blue food coloring) was pumped into the inlet aperture 36 through channel 35 at a constant flow rate of 12 µl/minute. Other flow rates were also used and no leakage was observed. Figure 13 provides a photomicrograph demonstrating water flowing through the channel and not leaking out.

Example 2

The procedures of Example 1 were used with the following exceptions. The channel was made 0.75" long and 0.009" wide, producing a channel volume of approximately 305 nl. The silicone rubber of Example 1 was replaced with a

and then cured in a 170°C oven for 30 minutes. Figure 14 provides a photomicrograph demonstrating water flowing through the channel and not leaking out.

Example 6

5 The procedures of Example 5 were used with the following exceptions. A 6% solution of Teflon® dispersed in Fluorinert® was used as a sealant coat material. When colored water was pumped through this channel, no leaking was observed.

Example 7

10 The procedures of Example 1 were used with the following exceptions. A 1% solution of Teflon® dispersed in Fluorinert® was used as a sealant coat material. The channel was formed from a 1 oz. (35 micron thick) copper laminate and was 0.25" long and 0.012" wide, resulting in a channel volume of approximately 68 nl. Two sealant coats were spin-deposited onto both surfaces.
15 When water was pumped through this channel, no leaking was observed.

Example 8

Referring to Figure 8, a microfluidic device designed for biochemical (e.g., protein) purification applications is shown. Two apertures 100 and 101 (40 mil diameter), representing inlet and outlet apertures, respectively, are drilled in a 1/8" thick polycarbonate substrate 102. Circuit board substrates comprising 1 oz. (35 micron thick) copper laminates on 0.062" thick FR-4 substrates, are coated as in Example 7. The filter "column" area 104 is filled with Bio-Gel HTP hydroxyapatite (Biorad, Hercules, CA). An 80 mil diameter aperture 106 is drilled in circuit board substrate 108, and a sheet of PTFE (25 micron pore size)
20 from Porex Technologies (Fairburn, GA) is used as the bottom substrate 110.
25 A 100 nl volume of protein solution in 10 mM phosphate buffer is added to the inlet aperture 100. The protein binds to the hydroxyapatite filter 104, while the other biomass does not. The volume of chamber 105 and the 80 mil hole 106

is adjusted to accommodate the sample volume (100 nl) and 4 equivalent washes with buffer (400 nl). Once this amount of fluid has washed the filter 104, 100 nl of higher salt concentration buffer is then injected. The molarity of the salt in the elution buffer will differ for different types of proteins; typically, 400 mM phosphate buffer is sufficient. This solution elutes the protein off the filter 104. The eluent is then collected at the outlet aperture 101. The bottom substrate 110 acts as a passive capillary valve by pumping the eluent through the outlet aperture 101 by capillary forces.

Example 9

A three-dimensional (3-D) microfluidic device was constructed comprising channels formed using both circuit board substrates and adhesive tape stencils. Referring to Figure 15A, which is an exploded perspective view of the individual components of the device, channels 150 and 151 were formed on a circuit board substrate 160 and coated with a silicone sealant coat as in Example 1. Inlet aperture 200 and outlet aperture 201 were formed through substrate 160 within channels 150 and 151, respectively. An acrylic cover plate substrate 202, having two apertures 204 and 205, was attached to the top of the coated circuit board channels 150 and 151, as in Example 1. A roughly horseshoe-shaped channel 206 was constructed in a stencil 208 cut from #444 double-sided tape (3M), and the stencil was aligned and adhered to the acrylic cover plate substrate 202. An acrylic cover plate substrate 210 was placed on the other side of the tape stencil 208. The assembled microfluidic device is shown in Figure 15B.

Fluid is injected at inlet aperture 200 and travels down the first circuit board channel 150. The fluid then travels through aperture 204, and then to and through the tape stencil channel 206. The fluid eventually passes through aperture 205 into the second circuit board channel 151 and exits through outlet aperture 201. A photomicrograph showing water flowing through such a device is shown in Figure 15C.

A device such as this can be used to perform electrophoretic or electrokinetic separation. Electrodes can be provided, for example, at the inlet and outlet apertures to apply the appropriate voltages. Since the optically transparent tape stencil layer 208 extends further than the optically opaque circuit board, analysis of the fluid contained in stencil channel 206 is possible using a variety of optical techniques.

Example 10

A microfluidic device capable of performing electrokinetic flow is constructed. Referring to Figure 16A, which is a top exploded perspective view, a microfluidic device comprising a circuit board substrate 300 having four round chambers 301 connected by flow channels 302 is shown. An electrode 304 is provided at each of the chambers 301 in order to perform electrokinetic flow, as described, for example, in United States Patent No. 5,750,015, the disclosure of which is incorporated herein by reference.

To construct the electrodes 304, holes (not shown) are formed in the circuit board laminate where the electrokinetic flow electrodes are to be located, and then soaked in a copper solution, which covers the inside surfaces of the holes. The surfaces are then patterned and etched to form copper lines defining the boundaries of the desired microstructure. A conductive epoxy is then screened into the holes that are to form the electrodes 304. Gold can then be plated onto the electrodes 304 to form a well-defined electrode surface. The edges of the electrodes 304 can be covered with a layer of solder mask, if so desired. A cover plate substrate 320 comprising, for example, glass or acrylic is placed on top of the circuit board substrate to "cap" the channels and chambers of the device. Apertures 322 are formed in the cover plate substrate 320 to align with the four chambers 301.

Electrochemical or other electrical sensing electrodes can also be constructed in this fashion. An array 310 of various electrodes can be placed within a chamber 312 in the manner described above. Electrical connections with

the electrodes 304 and the electrode array 310 can be made at the edge 314 of the circuit board 300; electrode lines are provided extending from the edge 314 to the individual electrodes (see Figure 16B, which is a bottom perspective view).

5 The present invention described and claimed herein is not to be limited in scope by the specific embodiments herein disclosed, since these embodiments are intended merely to illustrate certain aspects of the invention. All equivalent
embodiments are intended to be within the scope of this invention. Indeed,
various modifications of the invention in addition to those shown and described
10 herein will become apparent to those skilled in the art from the foregoing description. Such modifications are also intended to fall within the scope of the appended claims.

The disclosures of all references cited herein are incorporated by reference in their entireties.

WHAT IS CLAIMED IS:

1. A microfluidic device comprising:
 - a first substrate having on at least a first surface thereof at
5 least one microstructure adapted to support a fluid, the
microstructure being bounded by metallic features, such that the
metallic features and the first surface together define inner walls of
the microstructure; and
 - a second substrate sealed to the first substrate to define the
10 microstructure therebetween, the second substrate defining another
inner wall of the microstructure.
2. The microfluidic device of claim 1, wherein the first substrate
comprises a patterned metal laminate.
3. The microfluidic device of claim 1, wherein the first substrate
15 comprises an etched circuit board.
4. The microfluidic device of claim 3, wherein the etched circuit board
is prepared by chemical etching, plasma etching and/or reactive ion
etching.
5. The microfluidic device of claim 1, wherein at least one of the
20 metallic features comprise copper.
6. The microfluidic device of claim 1, wherein the first substrate
comprises a material selected from the group consisting of
polyimide, FR-4, ceramic, Teflon® and Kapton®.
7. The microfluidic device of claim 1, wherein the first substrate
25 comprises fiberglass.
8. The microfluidic device of claim 1, wherein the second substrate
comprises a material selected from the groups consisting of Mylar®,
polyester, glass, acrylic, polycarbonate and fiberglass.

9. The microfluidic device of claim 1, wherein the second substrate has on at least one surface thereof one or more microstructures adapted to support a fluid.
10. The microfluidic device of claim 1, wherein the sealing is provided by at least one intermediate sealant coat applied to at least a portion of at least one of the first substrate and the second substrate.
11. The microfluidic device of claim 1, wherein the sealant coat comprises a silicone material.
12. The microfluidic device of claim 1, wherein the sealant coat comprises one or more materials selected from the group consisting of Teflon®, Avatrel®, Liquin®, fluorocarbons, fluorothermoplastics, polyvinylidene fluorides, acrylics, waxes, epoxies, solders, polymers, paints, oils and varnishes.
13. The microfluidic device of claim 1, wherein the sealant coat is applied to a substrate by spin-deposition.
14. The microfluidic device of claim 1, wherein the sealant coat is applied to a substrate by spraying.
15. The microfluidic device of claim 1, wherein the sealant coat is applied to a substrate by dipping.
16. The microfluidic device of claim 1, wherein the microstructure comprises a channel or chamber.
17. The microfluidic device of claim 1, wherein the microstructure is at least partially filled with a filling material.
18. The microfluidic device of claim 17, wherein the filling material is a filter material.
19. The microfluidic device of claim 18, wherein the filter material is selected from the group consisting of polycarbonates, acrylics, acrylamides, polyurethanes, polyethylenes, polypropylenes, polyvinylidene fluorides, polytetrafluoroethylenes, naphion, nylons and polyethersulfones.

20. The microfluidic device of claim 18, wherein the filter material is selected from the group consisting of agarose, alginate, starch and carrageenan.
- 5 21. The microfluidic device of claim 18, wherein the filter material is selected from the group consisting of Sephadex® and Sephacil®.
22. The microfluidic device of claim 18, wherein the filter material is hydroxyapatite.
23. The microfluidic device of claim 17, wherein the filling material is applied by silk screening.
- 10 24. The microfluidic device of claim 1, wherein at least one substrate has one or more apertures.
25. The microfluidic device of claim 1, further comprising one or more valves.
- 15 26. The microfluidic device of claim 1, wherein the microstructure comprises a forked channel.
27. The microfluidic device of claim 1, further comprising at least one electrode.
28. The microfluidic device of claim 27, wherein the electrode is for detecting or measuring an electrical property of a fluid.
- 20 29. The microfluidic device of claim 27, wherein the electrode is for promoting electrophoretic or electrokinetic flow of a fluid.
30. The microfluidic device of claim 1, wherein at least a portion of at least one of the first substrate and the second substrate is adapted to permit transmission of an optical signal.
- 25 31. The microfluidic device of claim 1, further comprising one or more additional substrates sealingly engaged thereto.
32. The microfluidic device of claim 1, wherein a substrate has on a surface thereof a microstructure defined by a stencil.
- 30 33. A modular microfluidic device according to claim 1, adapted to connect to another microfluidic device.

34. A microfluidic system comprising a plurality of microfluidic devices according to claim 1, wherein at least two of the microfluidic devices are configured to enable fluid communication with each other.
- 5 35. The microfluidic system of claim 34, wherein two or more of the microfluidic devices are layered to form a three-dimensional microfluidic system.
36. A method for producing a microfluidic device, the method comprising the steps of:
- 10 preparing a first substrate having on at least a first surface thereof at least one microstructure adapted to support a fluid, the microstructure being bounded by metallic features, such that the metallic features and the first surface together define inner walls of the microstructure; and
- 15 sealing a second substrate to the first substrate to define the microstructure therebetween, the second substrate defining another inner wall of the microstructure.
37. The method of claim 36, wherein the sealing comprises applying at least one intermediate sealant coat to at least a portion of at least one of the first substrate and the second substrate.
- 20 38. The method of claim 36, wherein the first substrate is prepared by etching a circuit board comprising a metal laminate.
39. The method of claim 38, wherein the etching creates metallic features defining a microstructure.
- 25 40. A microfluidic device prepared according to the method of claim 36.
41. A mold prepared using at least a portion of the first substrate of claim 1 as a form for defining the mold.
42. The mold of claim 41, comprising a silicone material.

43. A microfluidic device comprising a microstructure prepared using the mold of claim 41.

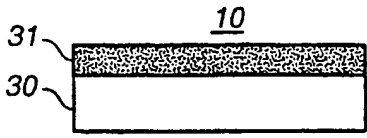

FIG._1A

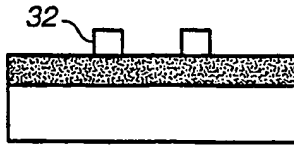

FIG._1B

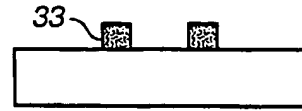

FIG._1C

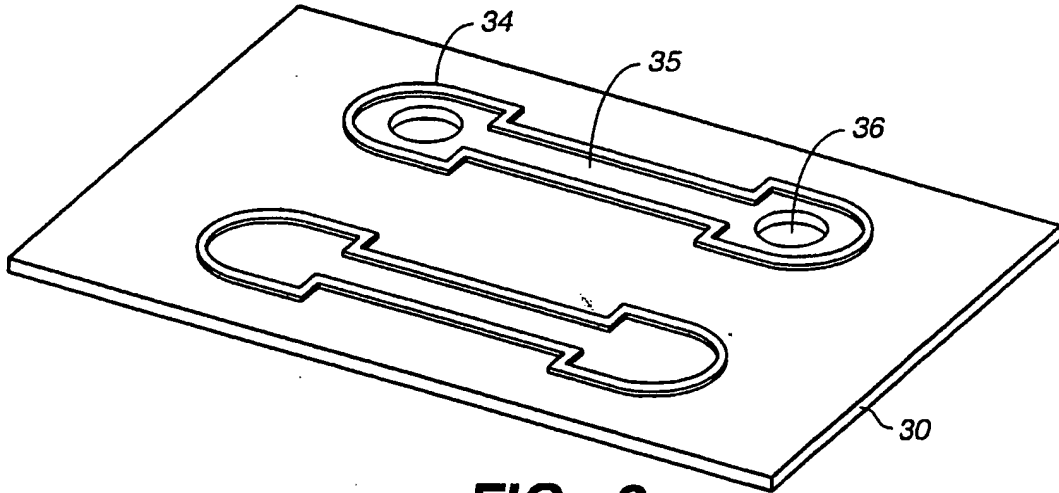

FIG._2

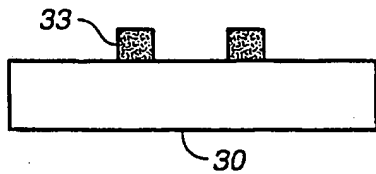

FIG._3A

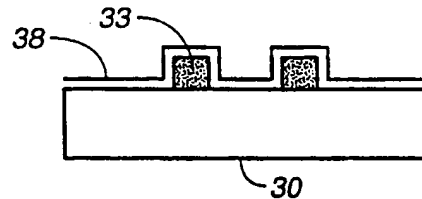

FIG._3B

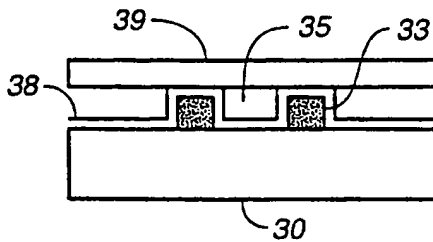

FIG._3C

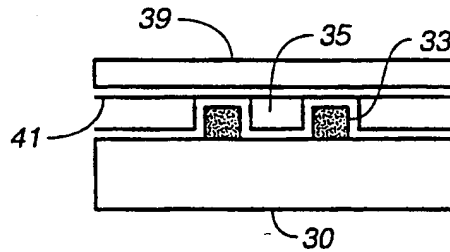

FIG._3D

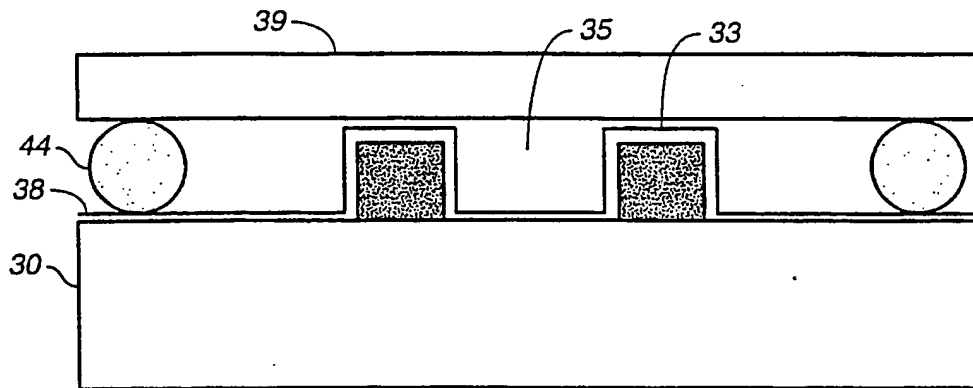

FIG. 4

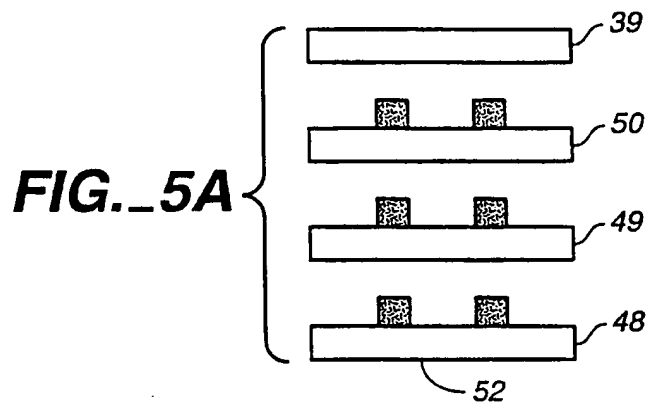

FIG. 5B

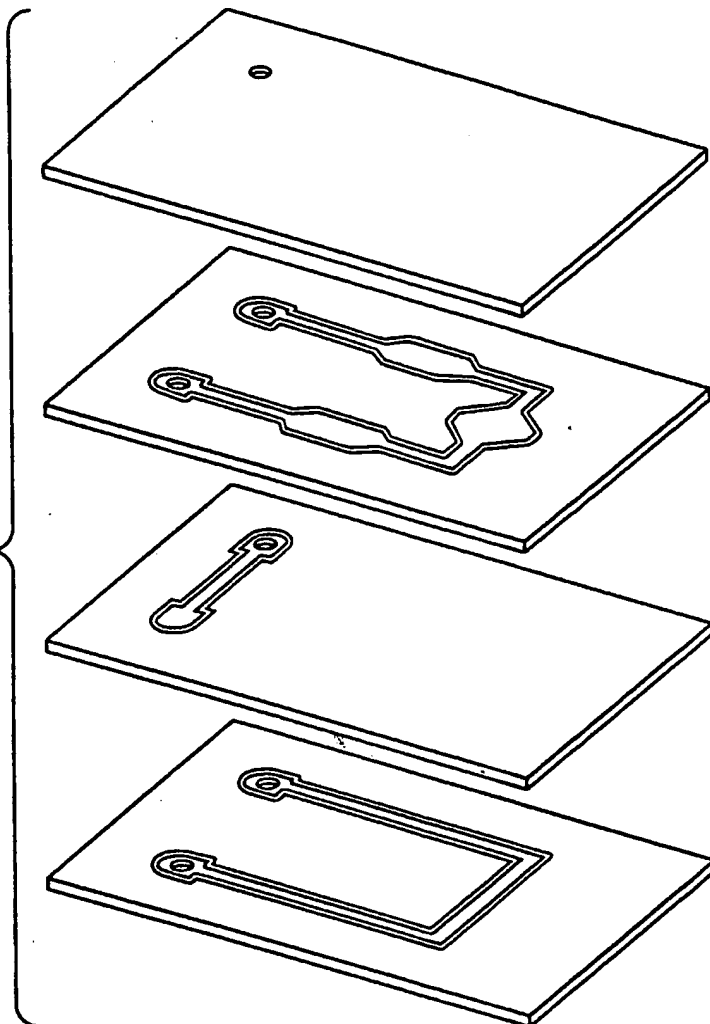

FIG. 6

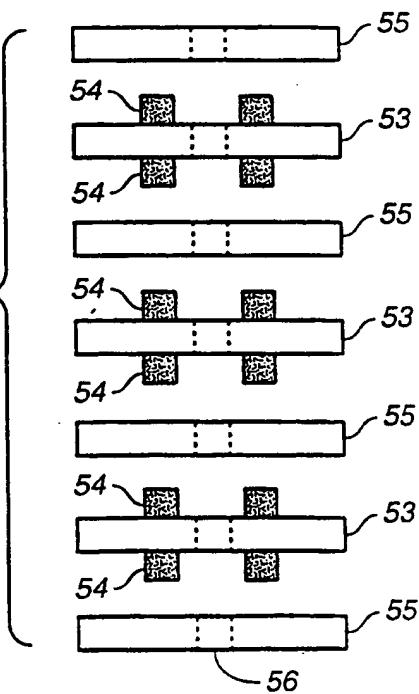
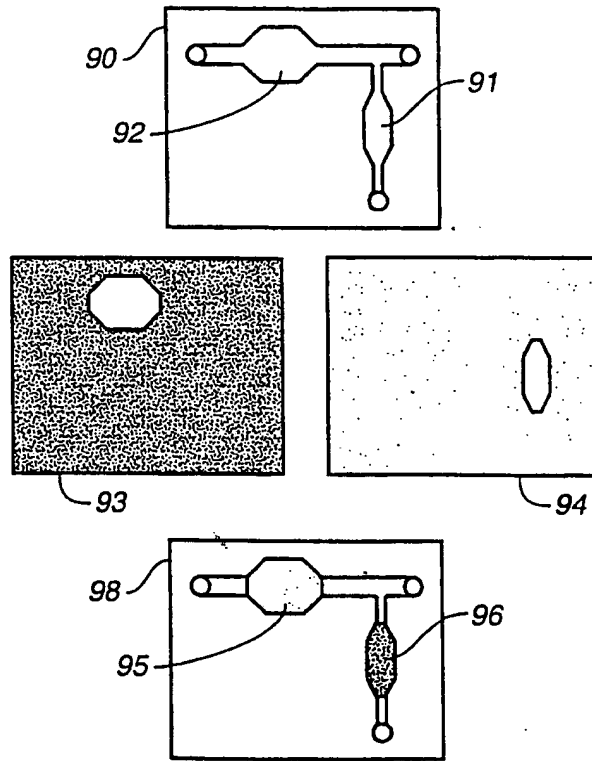

FIG. 7A



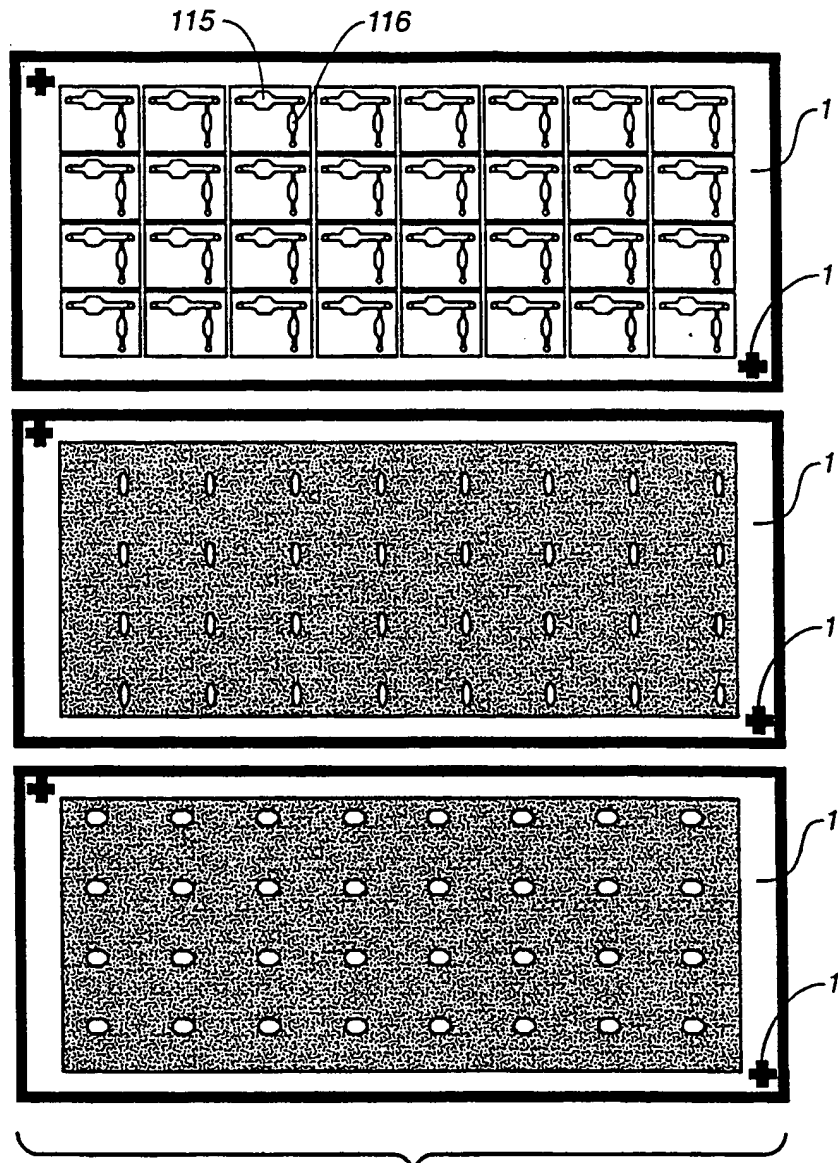
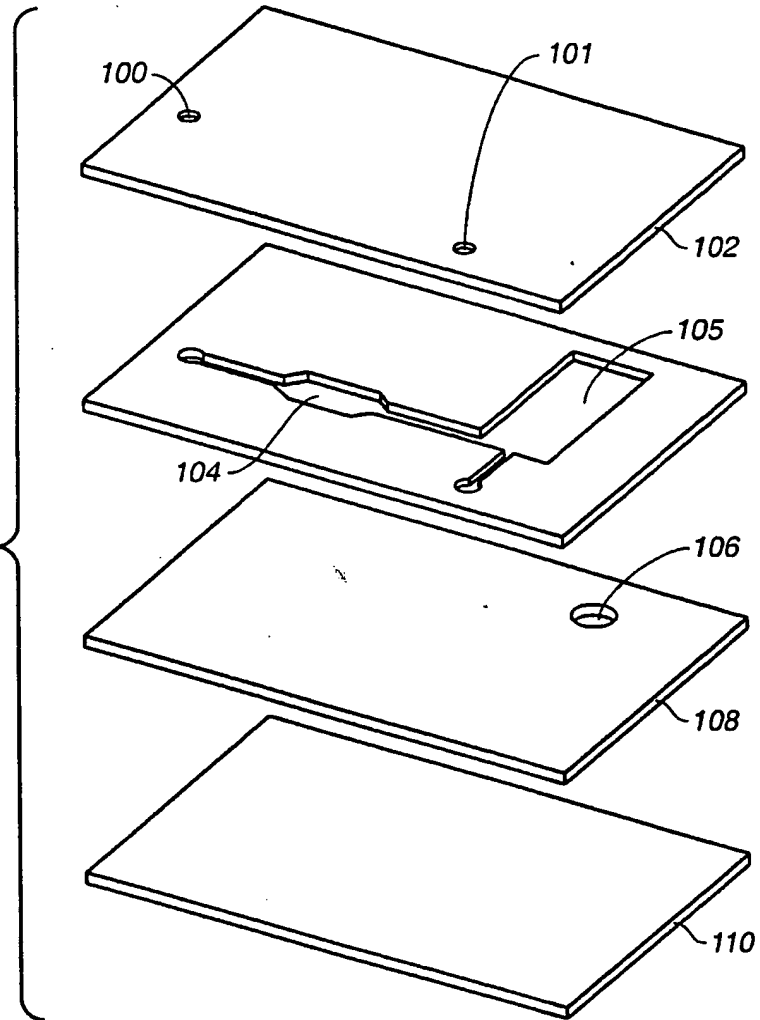

FIG. 7B

FIG._8



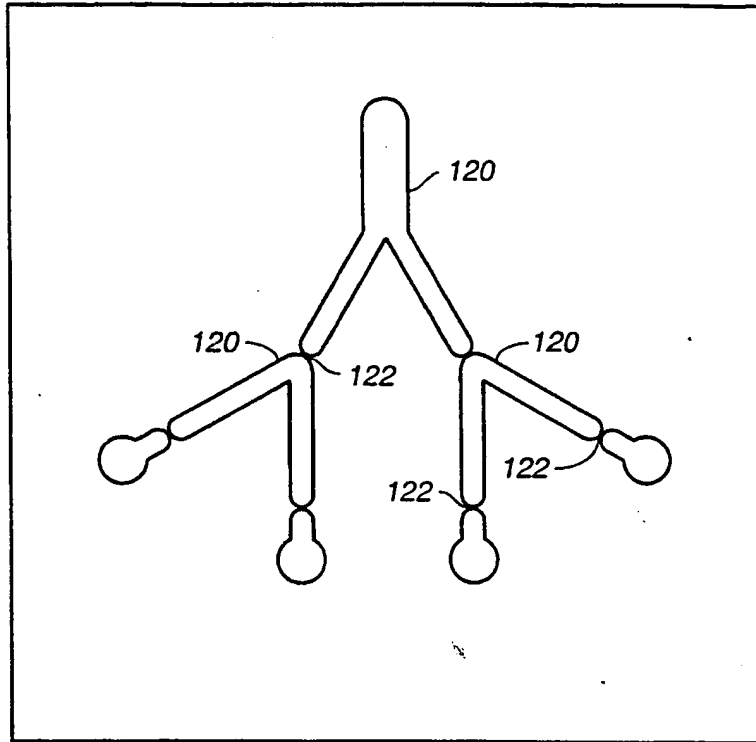

FIG. 9

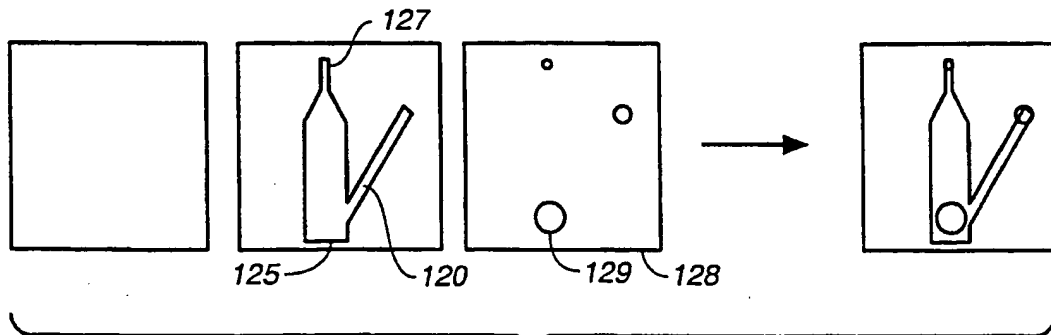

FIG. 10

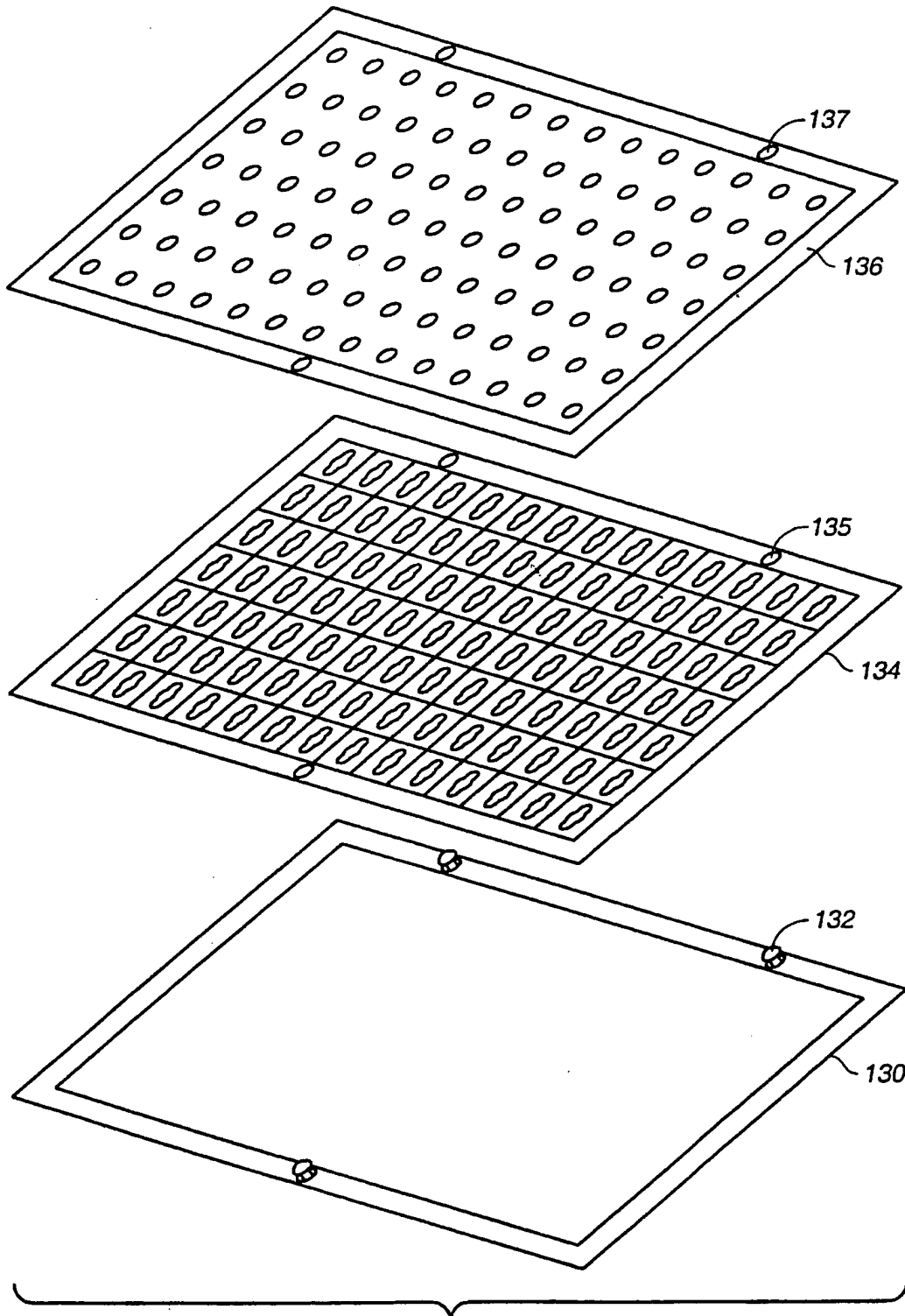

FIG. 11

9 / 12

FIG. 12A

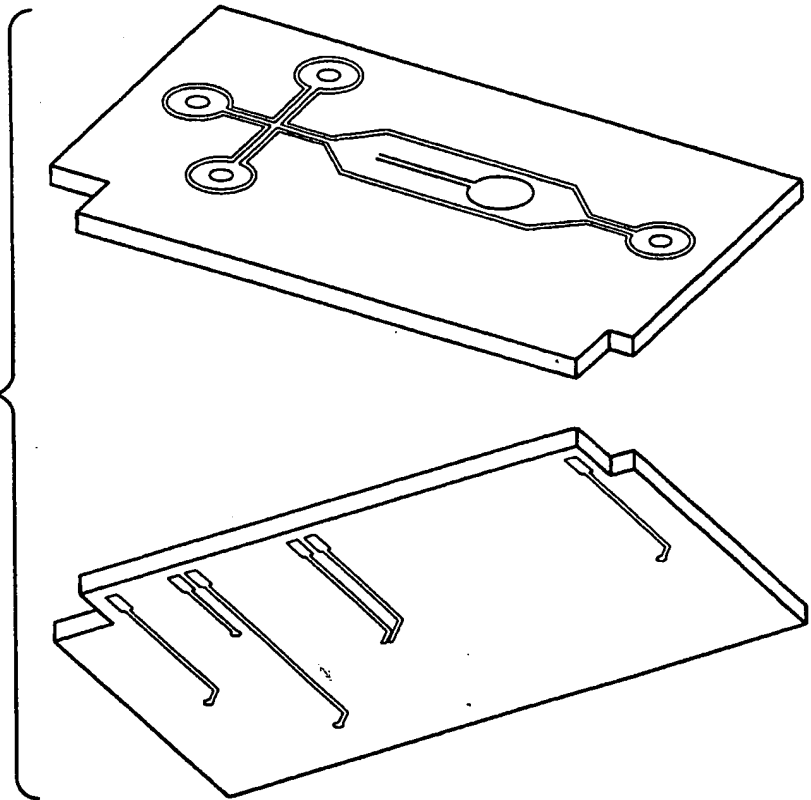

FIG. 12B

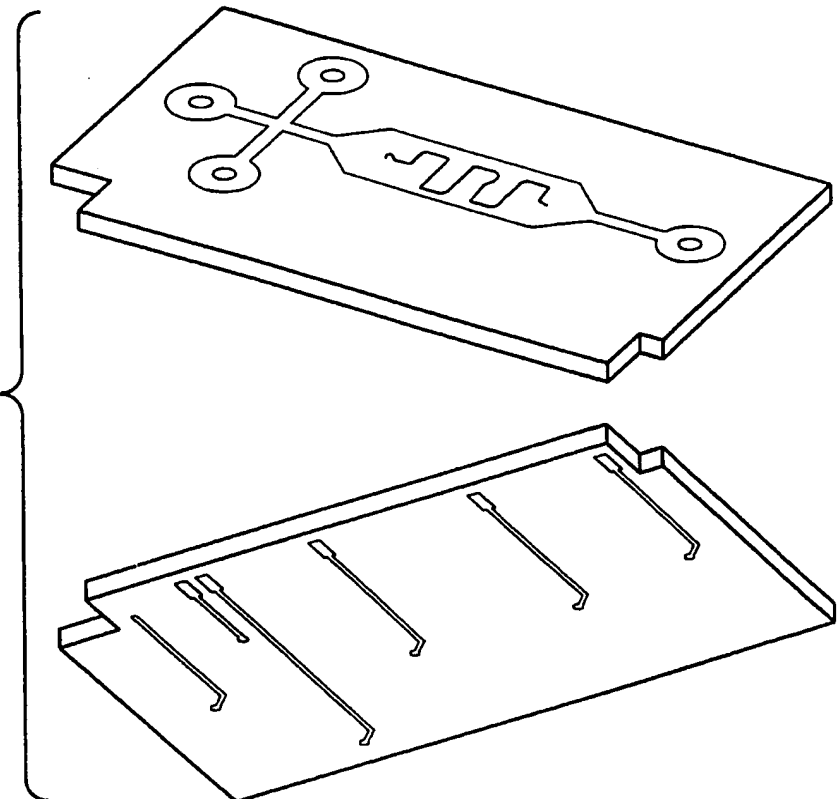

FIG._13

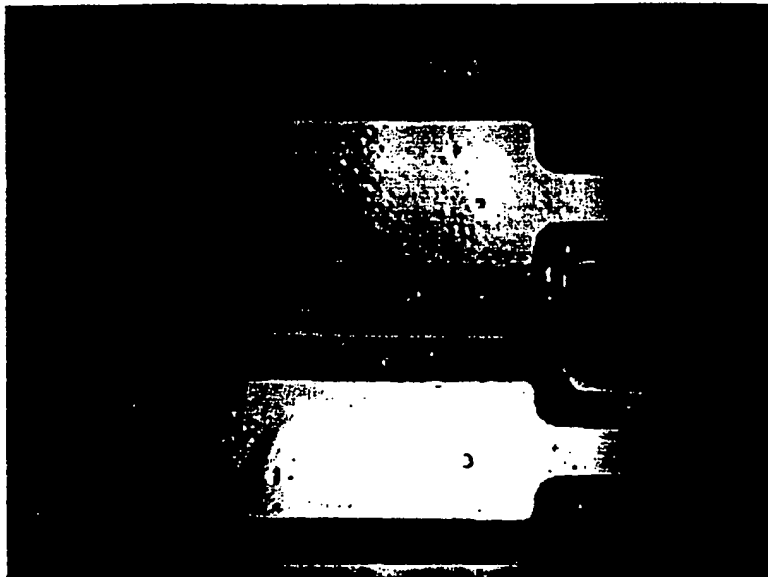

FIG._14

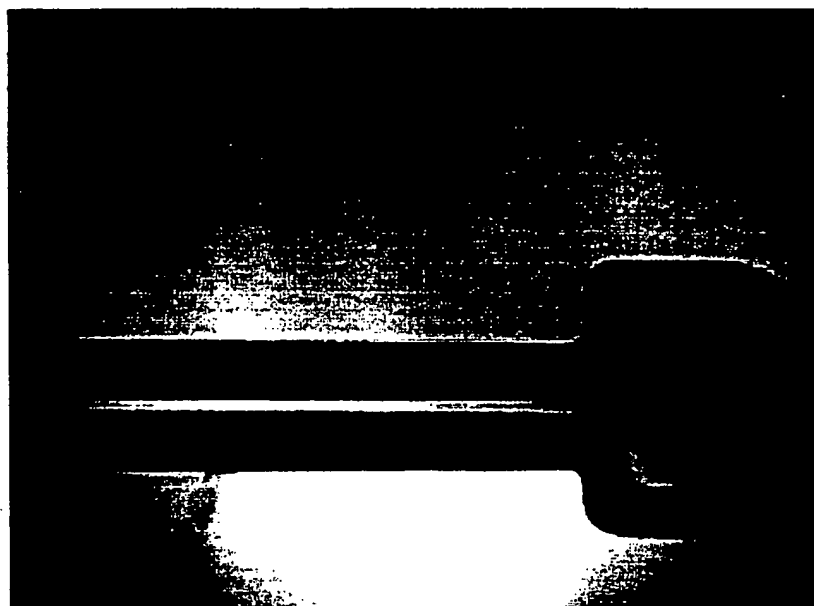

FIG._15C

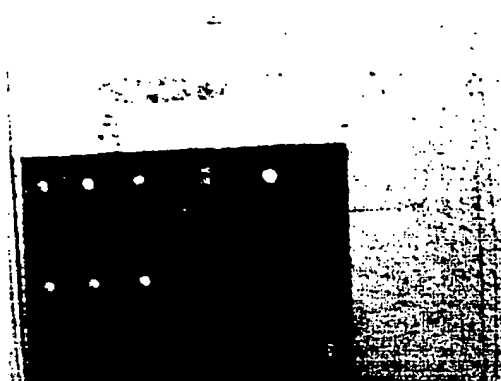

FIG. 15A

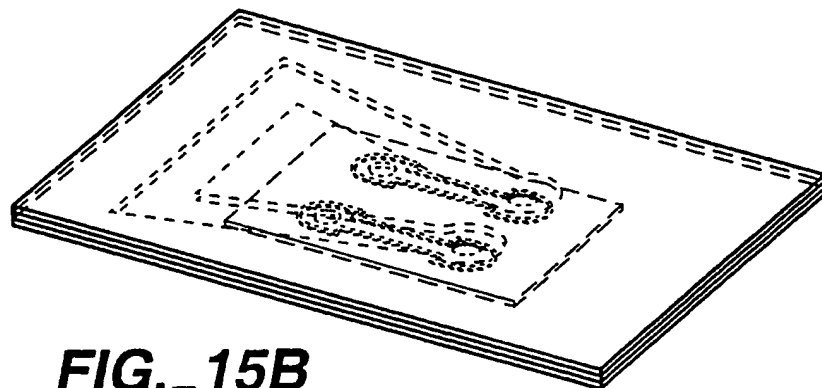
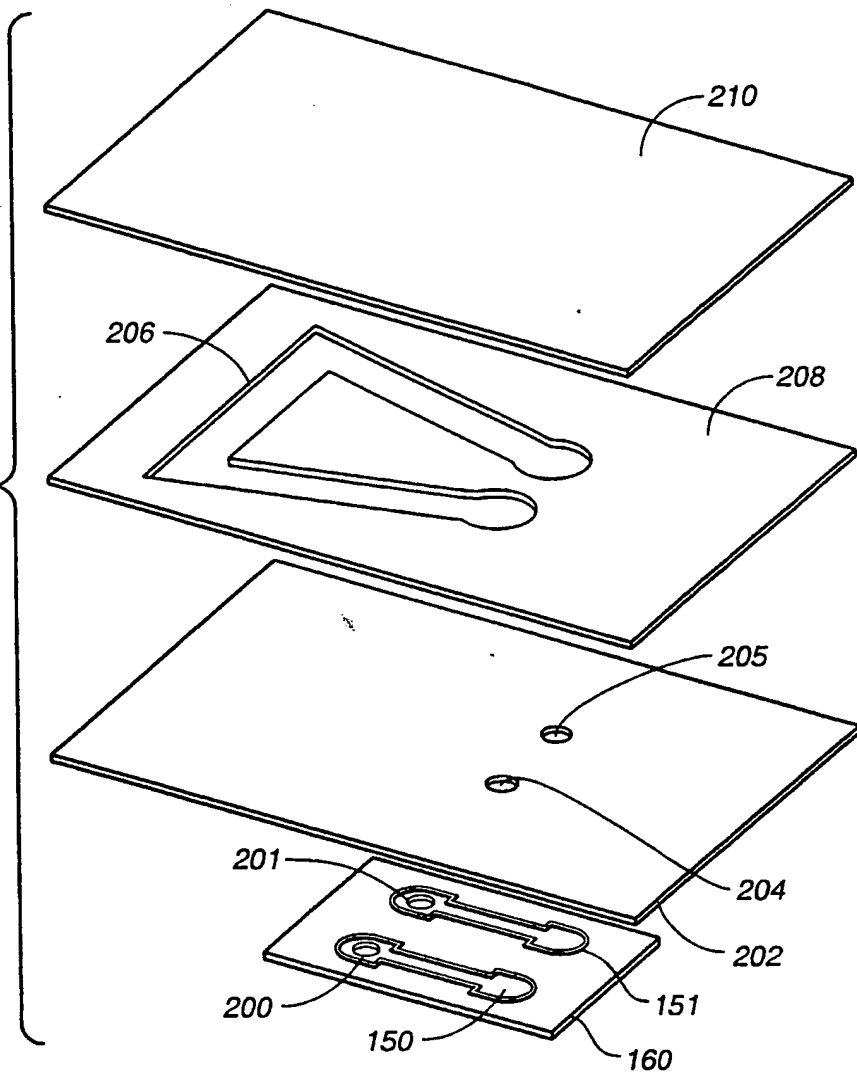

FIG. 15B

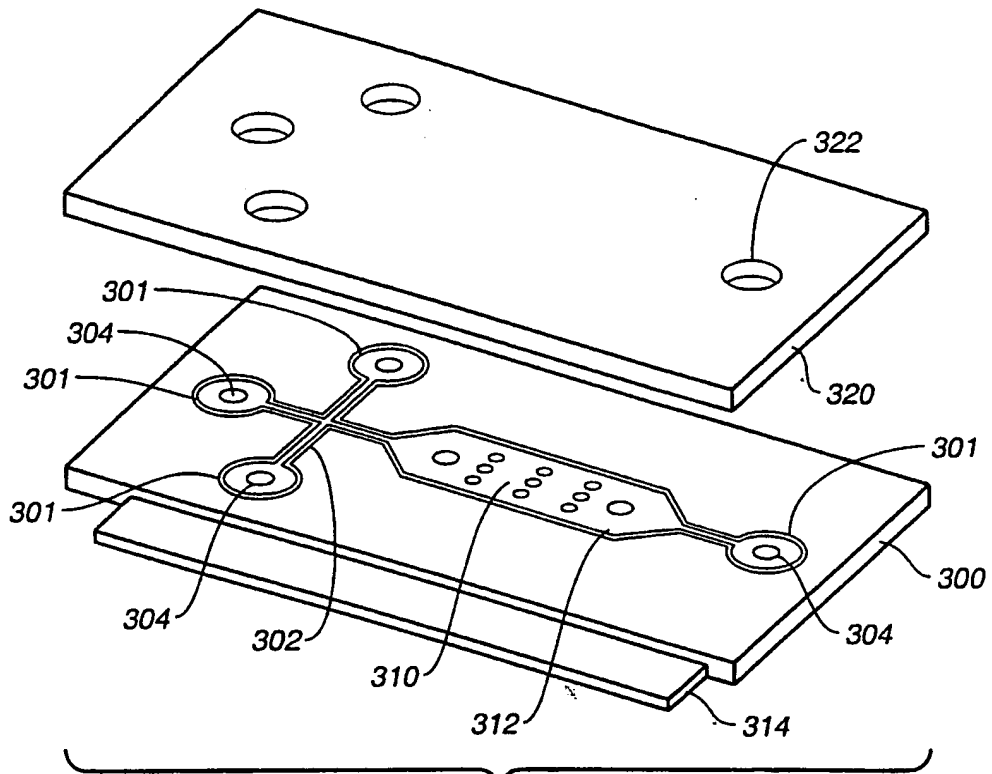

FIG. 16A

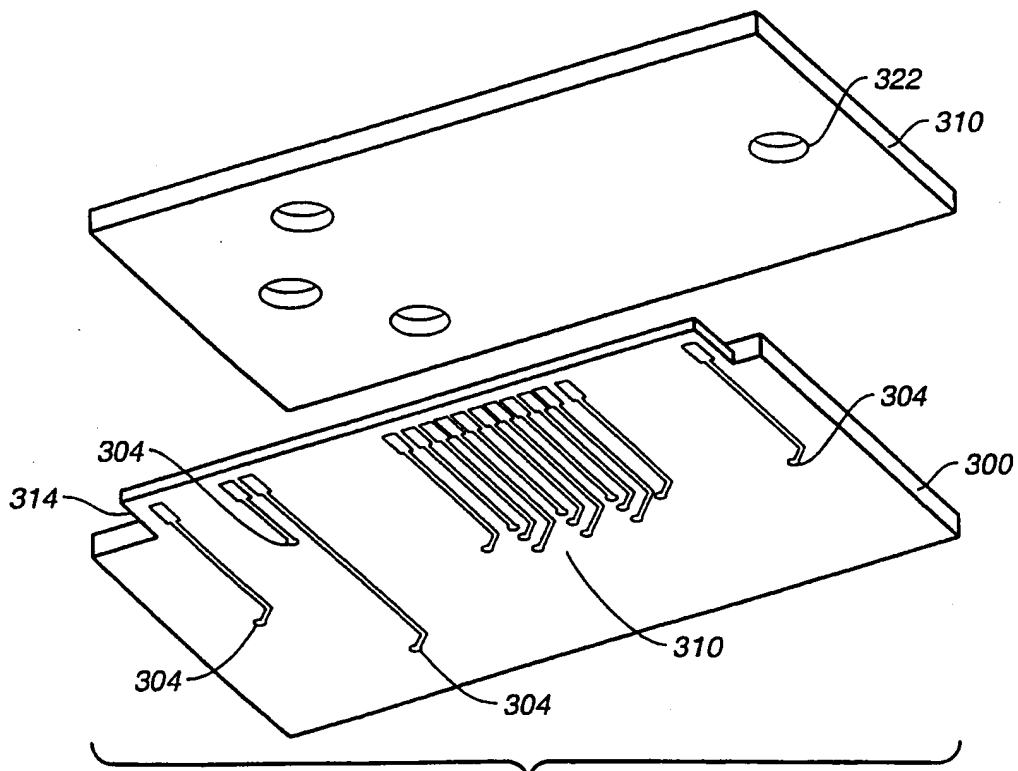

FIG. 16B

INTERNATIONAL SEARCH REPORT

International Application No

PCT/US 00/27313

A. CLASSIFICATION OF SUBJECT MATTER IPC 7 B81B1/00 G01N21/05 B01J19/00 B01L3/00		
According to International Patent Classification (IPC) or to both national classification and IPC		
B. FIELDS SEARCHED		
Minimum documentation searched (classification system followed by classification symbols) IPC 7 B81B G01N B01J B01L F15B B81C		
Documentation searched other than minimum documentation to the extent that such documents are included in the fields searched		
Electronic data base consulted during the international search (name of data base and, where practical, search terms used) EPO-Internal, PAJ, WPI Data		
C. DOCUMENTS CONSIDERED TO BE RELEVANT		
Category *	Citation of document, with indication, where appropriate, of the relevant passages	Relevant to claim No.
X	DE 197 39 722 A (FREDRICH) 1 April 1999 (1999-04-01) column 1, line 51 - line 64 column 2, line 2 - line 12 column 2, line 22 - line 29 figures 2,4	1-31, 33-40
X	DE 197 08 472 A (ATOTECH DEUTSCHLAND) 24 September 1998 (1998-09-24) abstract column 5, line 26 - line 35 figures 1,2	1-31, 33-40
A	US 5 858 194 A (BELL) 12 January 1999 (1999-01-12) column 6, line 49 - column 7, line 35; figures 7,9	17-23
--- -/--		
<input checked="" type="checkbox"/> Further documents are listed in the continuation of box C.		
<input checked="" type="checkbox"/> Patent family members are listed in annex.		
* Special categories of cited documents :		
A document defining the general state of the art which is not considered to be of particular relevance	*T* later document published after the international filing date or priority date and not in conflict with the application but cited to understand the principle or theory underlying the invention	
E earlier document but published on or after the international filing date	*X* document of particular relevance; the claimed invention cannot be considered novel or cannot be considered to involve an inventive step when the document is taken alone	
L document which may throw doubts on priority claim(s) or which is cited to establish the publication date of another citation or other special reason (as specified)	*Y* document of particular relevance; the claimed invention cannot be considered to involve an inventive step when the document is combined with one or more other such documents, such combination being obvious to a person skilled in the art.	
O document referring to an oral disclosure, use, exhibition or other means	*Z* document member of the same patent family	
P document published prior to the international filing date but later than the priority date claimed		
Date of the actual completion of the international search 15 February 2001	Date of mailing of the international search report 27/02/2001	
Name and mailing address of the ISA European Patent Office, P.B. 5818 Patentlaan 2 NL - 2280 HV Rijswijk Tel. (+31-70) 340-2040, Tx. 31 651 epo nl, Fax: (+31-70) 340-3016	Authorized officer SLEIGHTHOLME, G	

INTERNATIONAL SEARCH REPORT

International Application No

PCT/US 00/27313

C.(Continuation) DOCUMENTS CONSIDERED TO BE RELEVANT

Category	Citation of document, with indication, where appropriate, of the relevant passages	Relevant to claim No.
A	<p>MANZ A ET AL: "MICROMACHINING OF MONOCRYSTALLINE SILICON AND GLASS FOR CHEMICAL ANALYSIS SYSTEMS" TRAC, TRENDS IN ANALYTICAL CHEMISTRY,GB,ANALYTICAL CHEMISTRY. CAMBRIDGE, vol. 10, no. 5, 1 May 1991 (1991-05-01), pages 144-149, XP000201546 ISSN: 0165-9936 cited in the application abstract; figure 6</p>	1,36,41
A	<p>DUFFY ET AL: "Rapid Prototyping of Microfluidic Systems in Poly(dimethylsiloxane)" ANALYTICAL CHEMISTRY,AMERICAN CHEMICAL SOCIETY. COLUMBUS,US, vol. 70, 1998, pages 4974-4984, XP002149044 ISSN: 0003-2700 cited in the application abstract; figure 1</p>	1,36,41
A	<p>MARTYNOVA ET AL: "Fabrication of plastic microfluid channels by imprinting methods" ANALYTICAL CHEMISTRY, vol. 69, no. 23, 1997, pages 4783-4789, XP000955414 cited in the application abstract; figures 1,2</p>	1,36,41
A	<p>MCCORMICK R M ET AL: "MICROCHANNEL ELECTROPHORETIC SEPARATIONS OF DNA IN INJECTION-MOLDED PLASTIC SUBSTRATES" ANALYTICAL CHEMISTRY,US,AMERICAN CHEMICAL SOCIETY. COLUMBUS, vol. 69, no. 14, 15 July 1997 (1997-07-15), pages 2626-2630, XP000696569 ISSN: 0003-2700 cited in the application abstract</p>	1,36,41
A	<p>GONZALEZ C ET AL: "Fluidic interconnects for modular assembly of chemical microsystems" SENSORS AND ACTUATORS B,ELSEVIER SEQUOIA S.A., LAUSANNE,CH, vol. 49, no. 1-2, 25 June 1998 (1998-06-25), pages 40-45, XP004141435 ISSN: 0925-4005 cited in the application abstract</p>	1,36

-/--

INTERNATIONAL SEARCH REPORT

Inter national Application No PCT/US 00/27313

C.(Continuation) DOCUMENTS CONSIDERED TO BE RELEVANT

Category *	Citation of document, with indication, where appropriate, of the relevant passages	Relevant to claim No.
A	GB 2 252 844 A (S B SERVICES) 19 August 1992 (1992-08-19) page 3, line 4 -page 4, line 21; figures 2,3	1,36
A	WO 99 29497 A (CALIPER TECHN) 17 June 1999 (1999-06-17) abstract; figure 6	32

INTERNATIONAL SEARCH REPORT

Information on patent family members

International Application No

PCT/US 00/27313

Patent document cited in search report	Publication date	Patent family member(s)	Publication date
DE 19739722 A	01-04-1999	NONE	
DE 19708472 A	24-09-1998	WO 9837457 A EP 0961953 A	27-08-1998 08-12-1999
US 5858194 A	12-01-1999	EP 0912889 A WO 9803862 A	06-05-1999 29-01-1998
GB 2252844 A	19-08-1992	NONE	
WO 9929497 A	17-06-1999	US 6074725 A AU 1534799 A EP 1039995 A	13-06-2000 28-06-1999 04-10-2000